



SCORPION™

BY FLAMETECH

CUTTING TORCHES

THE BEST CUTTING
STINGER IN THE INDUSTRY

9600- HEAVY DUTY HAND CUTTING TORCH UP TO 60" OF CUTTING

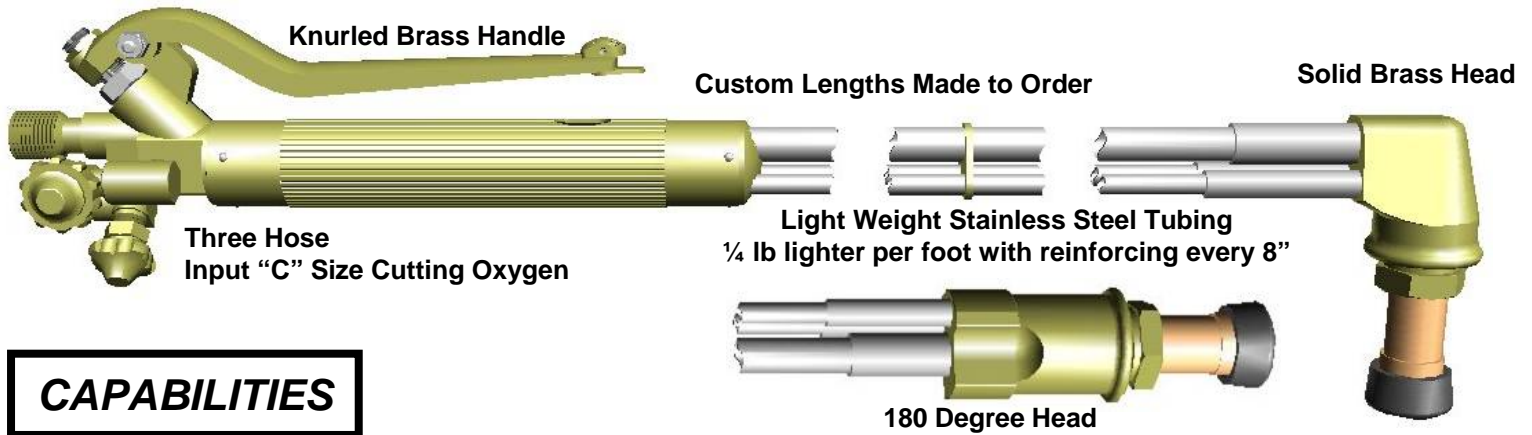

CAPABILITIES

The New Flame Tech® "9600" Hand Cutting Torch is a heavy duty torch designed for rugged steel mill environments. This heavy duty torch when using the NEW "BI-METAL" nozzles can hand cut up to 50" of steel.

- Three hose input into tail body.
- Uses common "C" size 1/2" cutting oxygen supply "B" 3/8" size fuel and 3/8" "B" preheat oxygen supply hose.
- Single lever actuated torch control.
- For alternative fuel only – NOT FOR ACETYLENE

TORCH FEATURES

- Heavy Duty Nozzle Mixing Torch
- Three Stainless Tubes in Triangular Format
- Light Weight Multi-Task Torch

ORDERING INFORMATION

Part #	Description
9648-70	= 96 indicates the torch series you are ordering
9648-70	= 48 indicates the length of the torch you are ordering (48" long)
9648-70	= 75 indicates the degree of the head (75, or 180) 180 Head shown above

Torches available in 36, 48, 60, 72, 96, 120, Custom lengths available contact Flame Tech @ (800) 749-3682

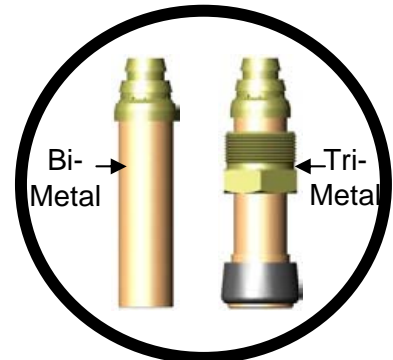

NEW "BI- & TRI METAL" SEAT MIXING CUTTING NOZZLE

BENEFITS

- Safety first - Reduced Flashback
- Maximum Strength, Greater Rigidity
- Low Maintenance, Longer Lasting
- Light weight easy to handle