

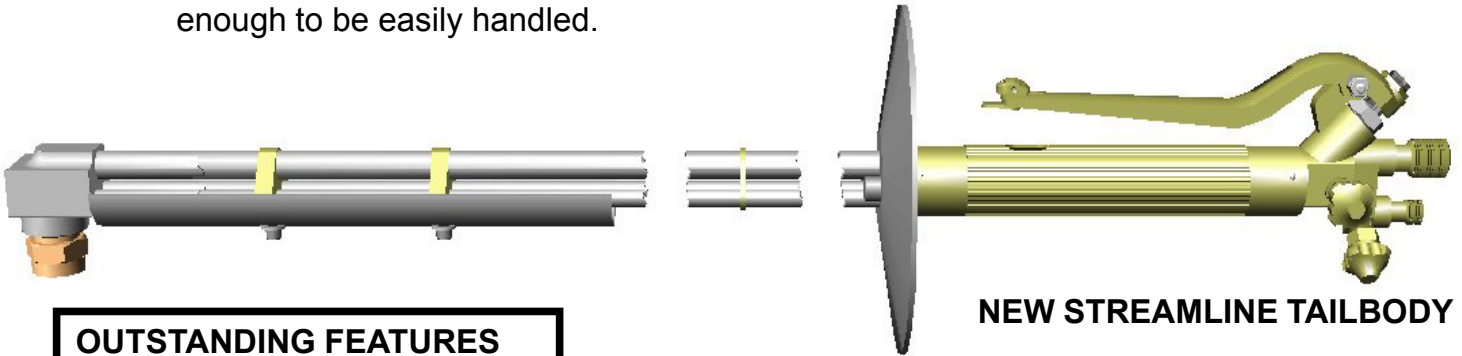

THE BEST CUTTING STINGER
IN THE INDUSTRY

EC-69F - HEAVY DUTY EMERGENCY CUT OFF TORCH UP TO 30" CUTTING

The Flame Tech® EC-69F Heavy Duty Emergency Cut-off Torch is the latest state-of-the-art steel mill emergency cut-off torch. The EC-69F offers the features and operational characteristics of a machine cut-off torch, yet is light enough to be easily handled.



NEW STREAMLINE TAILBODY

OUTSTANDING FEATURES

- Custom Lengths:** Available in any length. For 16 feet or longer, a reinforcing tube is recommended
- Light Weight:** Lengths up to 16 feet easily handled by a single operator.
- Fast Start:** Rapid preheat using cutting oxygen to assist start, decreased overall cutting time.
- Improved Cut Quality:** By utilizing the same tip as our caster torches, a superior edge is achieved.
- Longer Stand-Off** Longer tip life, less torch damage & wear.

NOZZLE INFORMATION

STYLE (Gega® Compatible)		SMCN-1	SMCN-2	SMCN-1	SMCN-2
		(SDS-26F) SMFNL-1	(SDS-33F) SMFNL-2	(SDS-36F) SMFNL-3	(SDS-403F) SMFNL-4
THICKNESS	(IN)	2 - 30	2 - 30	2 - 30	2 - 30
	(MM)	50 - 250	50 - 750	50 - 750	50 - 750
CUTTING OXYGEN PRESSURE	(PSI)	140 - 250	115 - 200	115 - 160	130 - 175
	(BAR)	9.7 - 17.4	8.0 - 13.9	8.0 - 11.1	9.0 - 12.0
NATURAL GAS PRESSURE	(PSI)	15 - 30	15 - 30	15 - 30	15 - 30
	(BAR)	1.0 - 2.1	1.0 - 2.1	1.0 - 2.1	1.0 - 2.1
CUTTING SPEED @ 20C-170F	(PSI)	6 - 11	7 - 9	7 - 9	7 - 11
	(BAR)	150 - 280	180 - 240	180 - 240	180 - 280
CUTTING SPEED @ 750-1400F	(PSI)	11 - 17	12 - 16	12 - 16	12 - 20
	(BAR)	280 - 440	300 - 400	300 - 400	300 - 520
NOZZLE	(IN/)	4 - 6	4 - 6	4 - 6	4 - 6
DISTANCE	(MM)	100 - 140	100 - 140	100 - 140	100 - 140