

**6000 SERIES—CUTS UP TO 8", GAS TYPE IS MODEL DEPENDENT (SEE BELOW)**

CGA "B" Oxygen &  
CGA "B" Left-hand Fuel Inlets

Knurled Brass Handle

Solid Bronze Forged Head

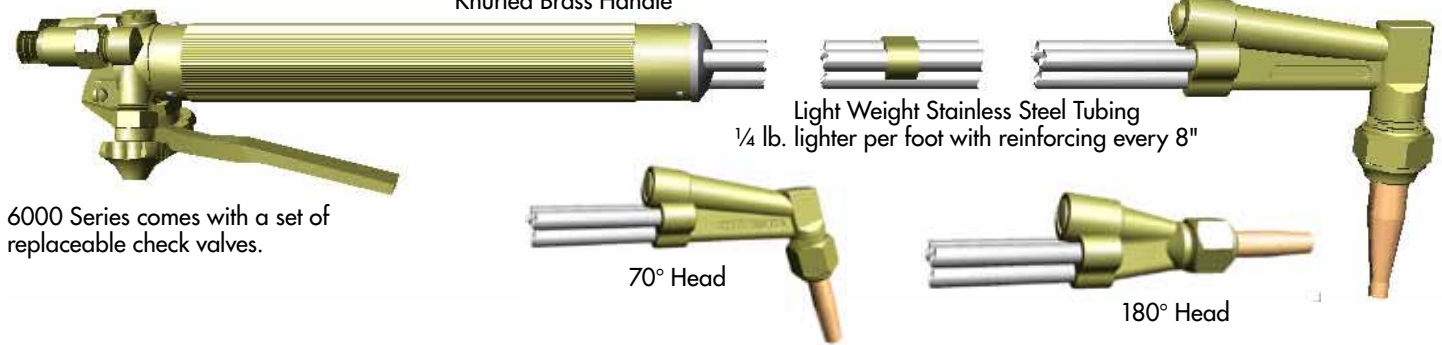

6000 Series comes with a set of replaceable check valves.

Light Weight Stainless Steel Tubing  
¼ lb. lighter per foot with reinforcing every 8"

70° Head

180° Head

**SOLID BRONZE FORGED HEAD**

- Long life, resists distortion from abuse
- Maximum service with minimum maintenance

**INJECTOR/MIXER**

- Mixer in head to reduce burn back in tubes
- Safer than tube mixing designs

**EXTERNAL CHECK VALVES**

- Easily replaced on the job & prevents reverse flow.
- Flame Tech® recommends flash arrestors style GG/DGN  
See check valves & flash arrestors section in this catalog.

**LIGHT WEIGHT, STAINLESS TUBES**

- Maximum design strength—¼ lb. per foot lighter

**MODELS & SIZES**

Flame Tech's 6000 series torches are designed for heavy duty hand held applications for the steel mill, foundry or scrap yard environment where up to 8" cutting is required. These torches come in 21, 27, 36, 48, 72, 96, & 120 inch lengths. Custom lengths are also available upon request. See our 7000, 8000 and 9000 series for 14", 36" & 48" cutting capabilities. These torches have built-in mixers, and as such must be ordered according to the gas type to be used. Different gas usage requires a different torch. See "Part Numbering Example."

**ORDERING & PART NUMBERS**

Flame Tech® uses an identification system that consists of numbers and letters to identify the manufacture model, size, gas, and style head on our torches. Below are examples for our Heavy Duty Hand Torches. See our price list for complete offering.

**OEM COMPATIBILITY**

- 6200 Series—Compatible with Harris® Seat
- 6300 Series—Compatible with Victor® Seat
- 6400 Series—Compatible with Oxweld® Seat



**PART NUMBERING EXAMPLE**

- 6321-A90 = "63" indicates the series of torch you are ordering (Victor® compatible torch)
- 6321-A90 = "21" indicates the length of torch you are ordering (21" long)
- 6321-A90 = "A" indicates Acetylene gas  
"F" indicates alternate Fuel gases only (not for acetylene) for maximum performance
- 6321-A90 = "90" indicates the degree of the head (70°, 90°, or 180°)

**» SEE PAGE 30 FOR SCRAPER TIP INFORMATION**

## FLAME TECH® SCRAPPER TIPS—6000, 6500 & 7500 SERIES TORCHES

### SEE THE DIFFERENCE YOURSELF WITH FLAME TECH'S FAMOUS "SCRAPPER" CUTTING TIPS

- Larger preheats reduce start time and help to "maintain the cut."
- Coarse "V" internal splines do not clog easily and can be cleaned with a pocket knife.
- Ideal for working on rusty, scaly, painted surfaces.
- Compatible with standard OEM torches.

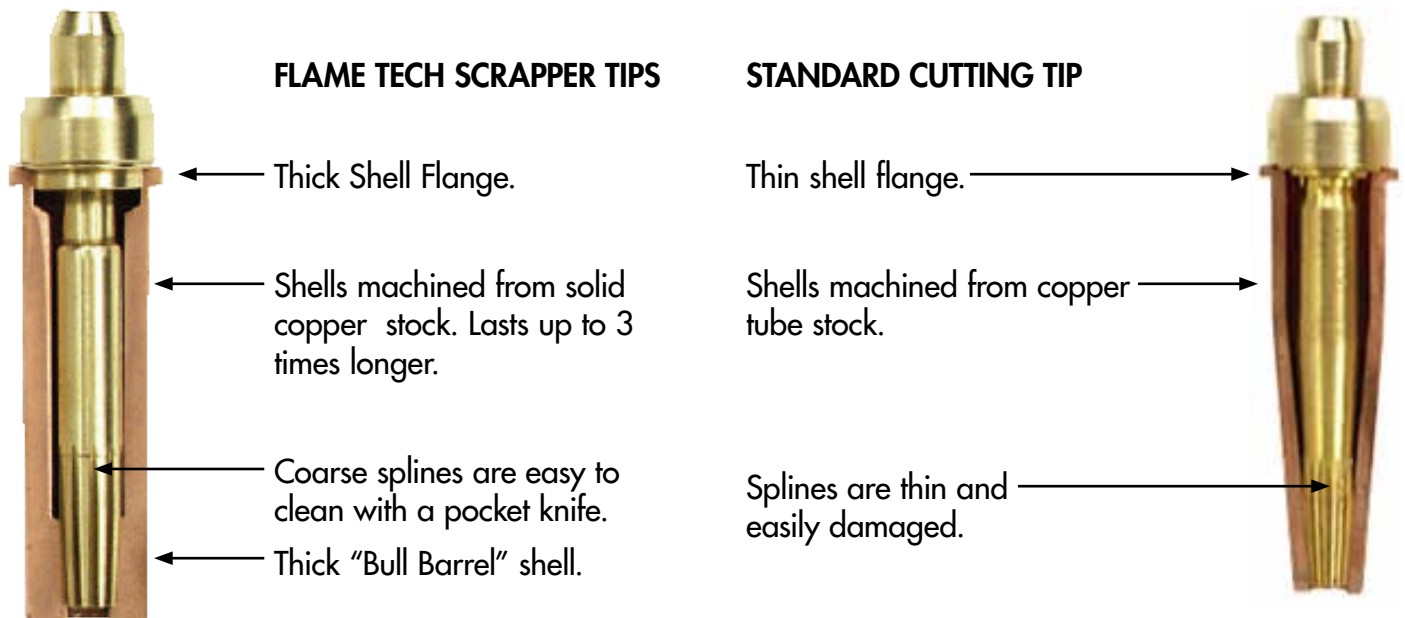

METAL THICKNESS (INCHES)	TIP SIZE		OXYGEN		FUEL GAS PSI	SPEED IPM	KERF WIDTH
	TIP NO.	DRILL SIZE	CUTTING PSI	PREHEAT PSI			
1/8	5/0	74	20-30	5-9	2-5	18-26	.035
3/16	4/0	71	30-40	5-9	2-5	18-25	.04
1/4	000	68	30-40	5-9	3-5	17-24	.05
3/8	00	64	35-45	5-10	3-5	17-23	.06
1/2	00½	62	35-45	5-10	3-6	16-22	.065
5/8	0	60	35-45	5-10	3-6	15-20	.07
3/4	0½	58	35-50	5-10	3-6	15-19	.075
1	1	56	35-50	5-10	3-6	14-18	.08
1½	1½	54	40-55	10-17	4-8	12-16	.09
2	2	52	40-55	10-17	4-8	10-14	.10
2½	2½	50	40-55	10-17	5-9	9-13	.105
3	3	48	45-60	10-17	6-10	8-11	.11
4	4	44	50-65	10-17	6-10	7-10	.13
6	5	39	60-75	10-17	8-12	5-8	.15
8	6	31	60-75	30-43	9-15	4-6	.19
9	7	28	55-65	30-43	9-15	3-5	.22
10	8	25	50-65	30-43	9-15	3-4	.24
12	10	13	45-60	30-43	10-18	2-3	.34
14	12	5	40-55	30-43	10-18	1-2	.40